



March 17, 2015

Brian Kennedy (LR-8J)
RCRA Branch
U.S. EPA, Region 5
77 West Jackson Blvd.
Chicago, IL 60604

RE: In the Matter of The Kraemer Company, LLC
U.S. EPA ID #: WIR000117010
Docket No: RCRA-05-2015-007
Respondent: The Kraemer Company, LLC

Dear Brian:

As required under the Consent Agreement and Final Order ("CAFO") executed by the parties in the above-referenced matter, please find The Kraemer Company, LLC's First SEP Report ("SEP Report") enclosed with this letter. The enclosed SEP Report addresses the requirements of Paragraph 69 of the CAFO by including:

- a. A detailed description of the installation of the Dillman Reverse Pulse Baghouse, Unit 8672;
- b. Itemized costs of goods and services used to complete the installation of the Dillman Reverse Pulse Baghouse, Unit 8672 documented by copies of invoices, purchase orders, or canceled checks that specifically identify and itemize the individual costs of the goods and services; and
- c. A Certification that The Kraemer Company, LLC has completed the installation of the Dillman Reverse Pulse Baghouse, Unit 8672 in compliance with this CAFO by a responsible corporate officer.

please feel free to reach out to Attorney Buck Sweeney if you have any questions or comments regarding the foregoing.

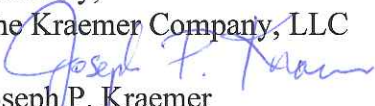
Sincerely,
The Kraemer Company, LLC

Joseph P. Kraemer
Vice President

Enc.

FIRST SEP REPORT CERTIFICATION

I certify that I am familiar with the information in this document and that, based on my inquiry of those individuals responsible for obtaining the information, it is true and complete to the best of my knowledge. I know that there are significant penalties for submitting false information, including the possibility of fines and imprisonment for knowing violations.

By: Joseph P. Kraemer
Name: JOSEPH P. KRAEMER
Title: VICE PRESIDENT
Date: 3/17/15

COMPLETION INITIAL INSTALLATION CERTIFICATION

I certify that The Kraemer Company, LLC has completed the initial installation of the Dillman Reverse Pulse Baghouse, Unit 8672 in compliance with this CAFO.

By: Joseph P. Kraemer
Name: JOSEPH P. KRAEMER
Title: VICE PRESIDENT
Date: 3/17/15



March 16, 2015

Mr. Brian Kennedy
U.S. EPA Region 5
77 West Jackson Blvd.
Chicago, IL 60604

RE: Docket No: RCRA-05-2015-0007
Description of Installation of Dillman Baghouse, Unit 8672

Mr. Kennedy,

The Dillman Reverse Pulse Baghouse, Unit 8672, is being used in connection with our Greyhawk Cage Mill Chassis, Unit 8671. The "Baghouse" is collecting the fine particles generated by the "Mill" to prevent them from being directly discharged into the air. The Baghouse is a separate unit on its own chassis that sets along the side of the Mill. The fine particulates created by the Mill are discharged through a closed conveyor system with one section cut open and a sealed knockout box placed over the top of this opening. This knockout box has a 24" opening with sealed ductwork and connections mounted to allow the transfer of the fine particles into the Baghouse. The Baghouse fan creates the suction that moves the fine particulate from the discharge of the Mill to the Baghouse. This fine particulate is collected in a series of bags inside the Baghouse. The Dillman Reverse Pulse process utilizes an air nozzle that is timed to pulse air into a row of bags to dislodge the fine particulate from the bags. This air nozzle moves from row to row through a series of fast acting doors to continuously dislodge the fine particulate from the bags. Once this material is released from the bags it is dropped to the floor of the Baghouse and collected by two augers on each side which transfers the material to a third auger that runs perpendicular and moves the material out of the Baghouse. The fine material is either blended back into the finished product by directly discharging it on the finished material conveyor belt or removed from the side of the Baghouse with a loader and added back into the finished material pile. The Baghouse will operate in conjunction with the Mill in accordance with the manufacturers specifications. Our Lime Mill Plant, which includes these two units along with others, is portable, and will be moved to numerous locations throughout the year. Each time we move the "Plant" the Baghouse and Mill will be disconnected and reconnected at the next location. The Plant, with the Baghouse was put into production in March of 2014. The Plant operation is seasonal and was not working through the winter. The Plant will be setup to run in March 2015.

Sincerely,
The Kraemer Company, LLC

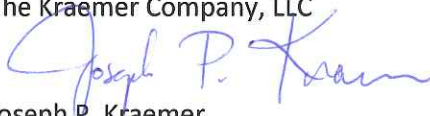
Joseph P. Kraemer
Vice President

Enc.



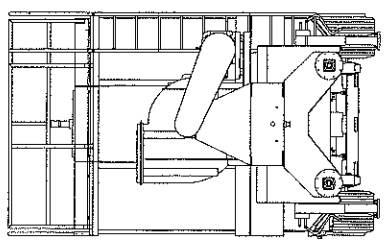
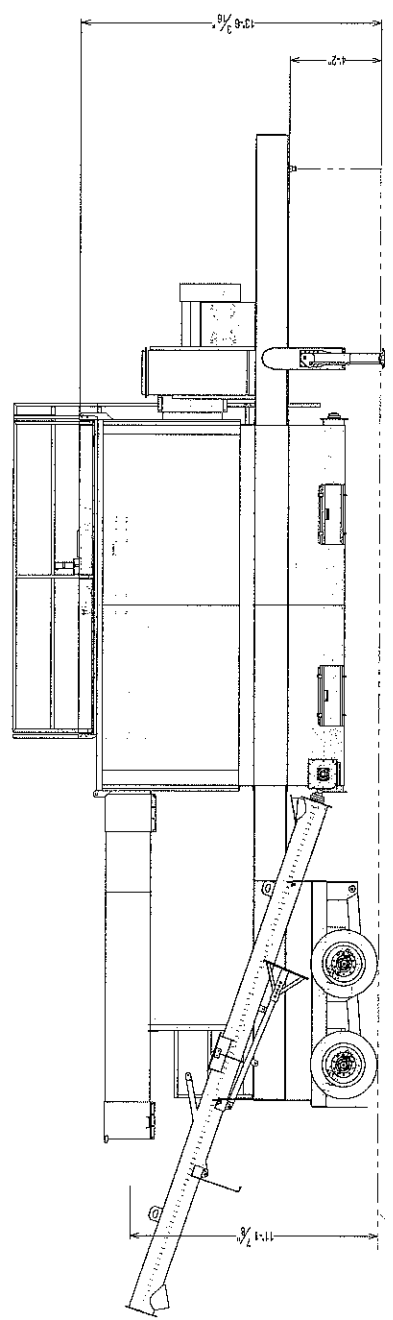
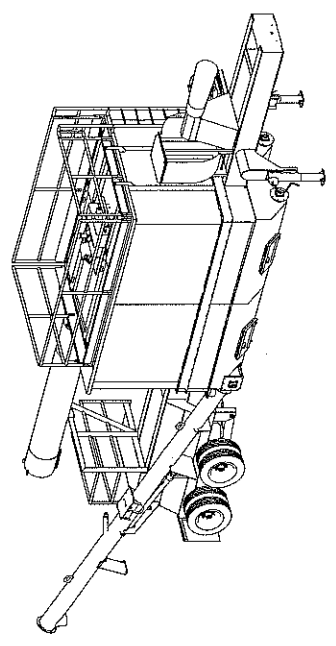
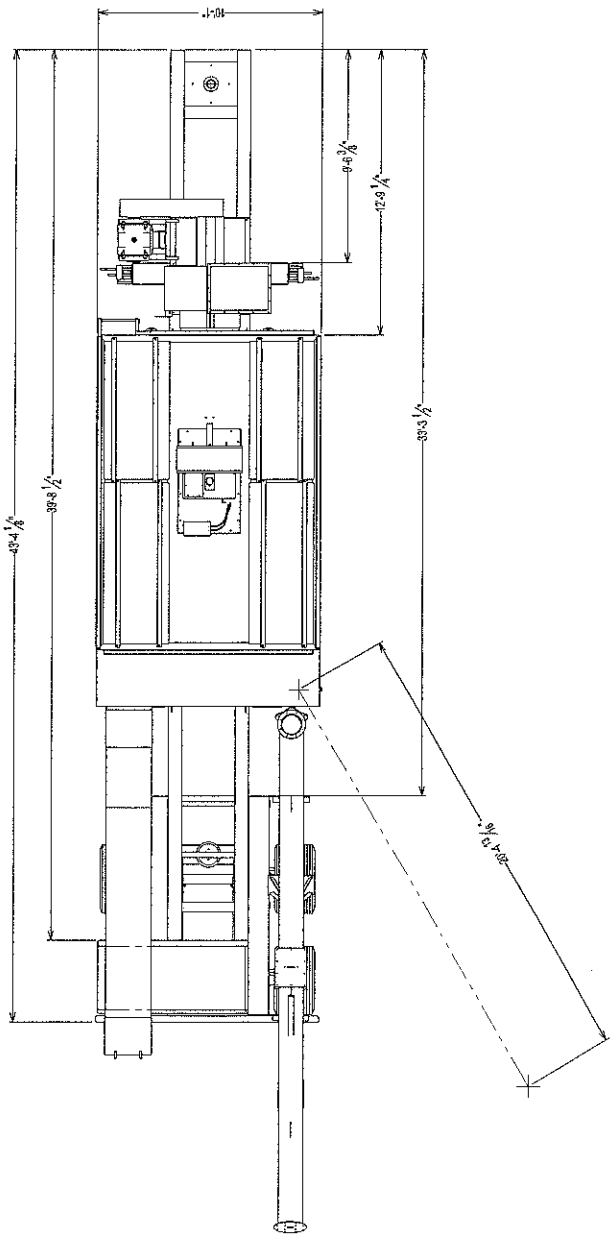

EXPLANATION: DIMENSIONS ARE PERFORMED BY THE DRAWING AND
 DIMENSIONS ARE TO CENTER UNLESS OTHERWISE SPECIFIED.
 THE DRAWING AND THE BARGE SHOWN HEREIN IS THE PROPERTY OF ASTEC INC.
 AND NO COPY THEREOF CAN BE MADE WITHOUT WRITTEN CONSENT.

DILLMAN
 2800 CHERRY STREET, CHRY, WI 53021

PROJECT: SINGLE MOD BARGEUSE
 DRAWING: BARGEUSE
 DATE: 07/20/04
 SHEET: 1 OF 1
 REVISION: 31/002.43
 BIDDING NO: B10000060A.01

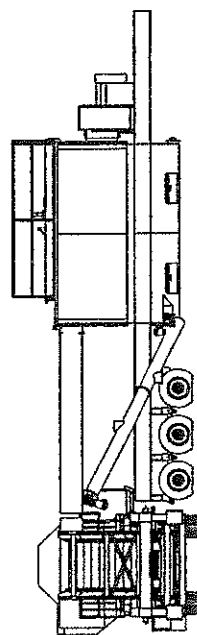
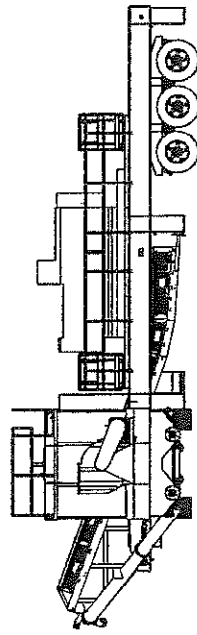
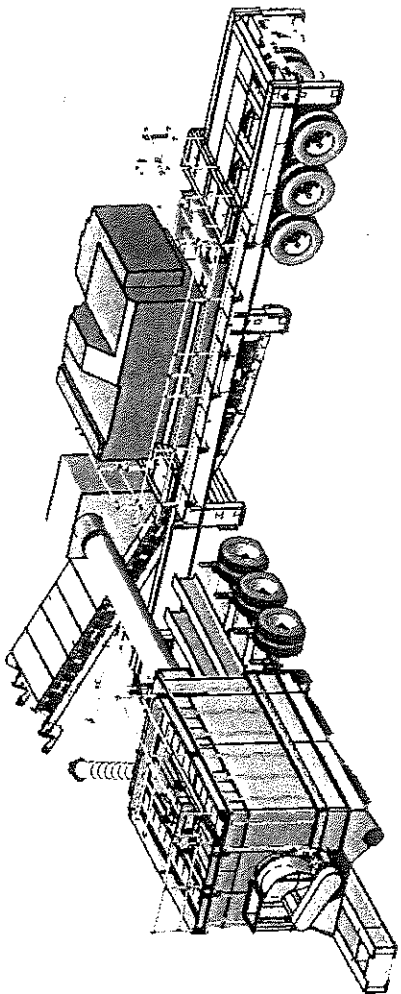
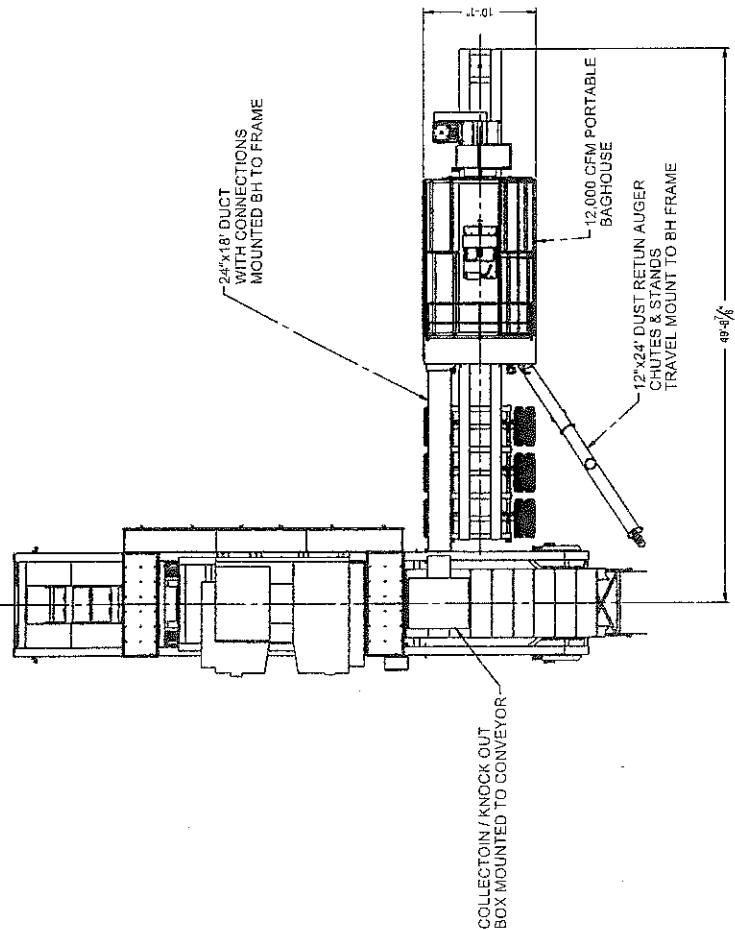

NOTE: THIS DRAWING IS A PRELIMINARY DESIGN. THE DESIGNER ASSUMES NO LIABILITY FOR THE ACCURACY OF THE INFORMATION CONTAINED HEREIN. THE USER OF THIS DRAWING SHALL BE RESPONSIBLE FOR OBTAINING ALL NECESSARY PERMITS AND APPROVALS FROM THE APPROPRIATE AGENCIES. THE USER SHALL BE RESPONSIBLE FOR OBTAINING ALL NECESSARY PERMITS AND APPROVALS FROM THE APPROPRIATE AGENCIES. THE USER SHALL BE RESPONSIBLE FOR OBTAINING ALL NECESSARY PERMITS AND APPROVALS FROM THE APPROPRIATE AGENCIES.

DILLMAN
 38000 Hwy 41, Fort Worth, TX 76120
 (817) 412-1111
 FAX (817) 412-1112
 WWW.DILLMAN.COM

PROJECT: 12,000 CFM PORTABLE RB BAGHOUSE
 DRAWING NO: 702744-LAYOUT 00
 DATE: 10/15/10
 SCALE: AS SHOWN
 SHEET NO: 1 OF 1

Work Order Cost Detail Report

Equipment	Equipment Description	Work Order	CT	Cost Type	Description	Date	Ref. 1	Ref. 1 Description	Ref. 2	Ref. 2 Description	Quantity	UOM	Unit Cost	Amount
867200	DILLMAN BAG HOUSE	1	01	Labor		03/21/2014 229		Henn, Ted	400	Shop Rate	3.00	Hours	26.40	\$79.20
867200	DILLMAN BAG HOUSE	1	01	Labor		03/20/2014 229		Henn, Ted	440	Ted Henn T/C Rate	4.50	Hours	27.40	\$123.30
867200	DILLMAN BAG HOUSE	1	01	Labor		03/20/2014 229		Henn, Ted	440	Ted Henn T/C Rate	1.00	Hours	41.10	\$41.10
867200	DILLMAN BAG HOUSE	1	01	Labor		03/20/2014 229		Henn, Ted	400	Shop Rate	3.50	Hours	39.60	\$138.60
867200	DILLMAN BAG HOUSE	1	01	Labor		03/19/2014 229		Henn, Ted	440	Ted Henn T/C Rate	1.00	Hours	27.40	\$27.40
867200	DILLMAN BAG HOUSE	1	01	Labor		03/19/2014 229		Henn, Ted	440	Ted Henn T/C Rate	2.00	Hours	41.10	\$82.20
867200	DILLMAN BAG HOUSE	1	01	Labor		03/18/2014 229		Henn, Ted	400	Shop Rate	8.00	Hours	26.40	\$211.20
867200	DILLMAN BAG HOUSE	1	01	Labor		03/18/2014 229		Henn, Ted	400	Shop Rate	1.00	Hours	39.60	\$39.60
867200	DILLMAN BAG HOUSE	1	01	Labor		03/18/2014 269		Ruhland, Steven	442	Steve Ruhland T/C Rate	1.00	Hours	42.75	\$42.75
867200	DILLMAN BAG HOUSE	1	01	Labor		03/17/2014 229		Henn, Ted	400	Shop Rate	8.00	Hours	26.40	\$211.20
867200	DILLMAN BAG HOUSE	1	01	Labor		03/17/2014 229		Henn, Ted	400	Shop Rate	1.00	Hours	39.60	\$39.60
867200	DILLMAN BAG HOUSE	1	01	Labor		03/14/2014 211		Bindl, Daniel	400	Shop Rate	8.00	Hours	19.97	\$159.76
867200	DILLMAN BAG HOUSE	1	01	Labor		03/14/2014 211		Bindl, Daniel	400	Shop Rate	1.00	Hours	29.96	\$29.96
867200	DILLMAN BAG HOUSE	1	01	Labor		03/14/2014 228		Gruber, Eric	400	Shop Rate	8.00	Hours	17.33	\$138.64
867200	DILLMAN BAG HOUSE	1	01	Labor		03/14/2014 228		Gruber, Eric	400	Shop Rate	1.00	Hours	25.99	\$25.99
867200	DILLMAN BAG HOUSE	1	01	Labor		03/14/2014 229		Henn, Ted	400	Shop Rate	5.00	Hours	26.40	\$132.00
867200	DILLMAN BAG HOUSE	1	01	Labor		03/14/2014 229		Henn, Ted	400	Shop Rate	1.00	Hours	39.60	\$39.60
867200	DILLMAN BAG HOUSE	1	01	Labor		03/14/2014 269		Ruhland, Steven	420	Steven Ruhland-Shop Rate	3.00	Hours	27.50	\$82.50
867200	DILLMAN BAG HOUSE	1	01	Labor		03/14/2014 272		Richards, Randy	400	Shop Rate	8.00	Hours	25.38	\$203.04
867200	DILLMAN BAG HOUSE	1	01	Labor		03/14/2014 272		Richards, Randy	400	Shop Rate	1.00	Hours	38.07	\$38.07
867200	DILLMAN BAG HOUSE	1	01	Labor		03/13/2014 211		Bindl, Daniel	400	Shop Rate	1.00	Hours	29.95	\$29.95
867200	DILLMAN BAG HOUSE	1	01	Labor		03/13/2014 228		Gruber, Eric	400	Shop Rate	3.00	Hours	17.33	\$51.99
867200	DILLMAN BAG HOUSE	1	01	Labor		03/13/2014 229		Henn, Ted	400	Shop Rate	3.00	Hours	26.40	\$79.20
867200	DILLMAN BAG HOUSE	1	01	Labor		03/13/2014 229		Henn, Ted	400	Shop Rate	1.00	Hours	39.60	\$39.60
867200	DILLMAN BAG HOUSE	1	01	Labor		03/13/2014 272		Richards, Randy	400	Shop Rate	1.50	Hours	38.07	\$57.11
867200	DILLMAN BAG HOUSE	1	01	Labor		03/06/2014 269		Ruhland, Steven	420	Steven Ruhland-Shop Rate	5.00	Hours	27.50	\$137.50
867200	DILLMAN BAG HOUSE	1	01	Labor							84.50		\$2,281.06	
867200	DILLMAN BAG HOUSE	1	02	Labor Burden		03/21/2014 229		Henn, Ted	400	Shop Rate	3.00	Hours	6.29	\$18.88
867200	DILLMAN BAG HOUSE	1	02	Labor Burden		03/20/2014 229		Henn, Ted	440	Ted Henn T/C Rate	4.50	Hours	6.53	\$29.38
867200	DILLMAN BAG HOUSE	1	02	Labor Burden		03/20/2014 229		Henn, Ted	440	Ted Henn T/C Rate	1.00	Hours	8.89	\$8.89
867200	DILLMAN BAG HOUSE	1	02	Labor Burden		03/20/2014 229		Henn, Ted	400	Shop Rate	3.50	Hours	8.56	\$29.97
867200	DILLMAN BAG HOUSE	1	02	Labor Burden		03/19/2014 229		Henn, Ted	440	Ted Henn T/C Rate	1.00	Hours	6.53	\$6.53
867200	DILLMAN BAG HOUSE	1	02	Labor Burden		03/19/2014 229		Henn, Ted	440	Ted Henn T/C Rate	2.00	Hours	8.89	\$17.78
867200	DILLMAN BAG HOUSE	1	02	Labor Burden		03/18/2014 229		Henn, Ted	400	Shop Rate	8.00	Hours	6.29	\$50.32
867200	DILLMAN BAG HOUSE	1	02	Labor Burden		03/18/2014 269		Henn, Ted	400	Shop Rate	1.00	Hours	8.56	\$8.56
867200	DILLMAN BAG HOUSE	1	02	Labor Burden		03/17/2014 229		Henn, Ted	442	Steve Ruhland T/C Rate	1.00	Hours	9.42	\$9.42
867200	DILLMAN BAG HOUSE	1	02	Labor Burden		03/17/2014 229		Henn, Ted	400	Shop Rate	8.00	Hours	6.29	\$50.32
867200	DILLMAN BAG HOUSE	1	02	Labor Burden		03/17/2014 229		Henn, Ted	400	Shop Rate	1.00	Hours	8.56	\$8.56
867200	DILLMAN BAG HOUSE	1	02	Labor Burden		03/14/2014 211		Bindl, Daniel	400	Shop Rate	8.00	Hours	4.93	\$39.47
867200	DILLMAN BAG HOUSE	1	02	Labor Burden		03/14/2014 211		Bindl, Daniel	400	Shop Rate	1.00	Hours	6.73	\$6.73
867200	DILLMAN BAG HOUSE	1	02	Labor Burden		03/14/2014 228		Gruber, Eric	400	Shop Rate	8.00	Hours	4.00	\$31.99
867200	DILLMAN BAG HOUSE	1	02	Labor Burden		03/14/2014 228		Gruber, Eric	400	Shop Rate	1.00	Hours	5.42	\$5.42
867200	DILLMAN BAG HOUSE	1	02	Labor Burden		03/14/2014 229		Henn, Ted	400	Shop Rate	5.00	Hours	6.32	\$31.58
867200	DILLMAN BAG HOUSE	1	02	Labor Burden		03/14/2014 229		Henn, Ted	400	Shop Rate	1.00	Hours	8.67	\$8.67
867200	DILLMAN BAG HOUSE	1	02	Labor Burden		03/14/2014 269		Ruhland, Steven	420	Steven Ruhland-Shop Rate	3.00	Hours	6.57	\$19.72
867200	DILLMAN BAG HOUSE	1	02	Labor Burden		03/14/2014 272		Richards, Randy	400	Shop Rate	8.00	Hours	6.42	\$51.32
867200	DILLMAN BAG HOUSE	1	02	Labor Burden		03/14/2014 272		Richards, Randy	400	Shop Rate	1.00	Hours	8.77	\$8.77
867200	DILLMAN BAG HOUSE	1	02	Labor Burden		03/13/2014 211		Bindl, Daniel	400	Shop Rate	1.00	Hours	6.75	\$6.75
867200	DILLMAN BAG HOUSE	1	02	Labor Burden		03/13/2014 228		Gruber, Eric	400	Shop Rate	3.00	Hours	4.00	\$12.00
867200	DILLMAN BAG HOUSE	1	02	Labor Burden		03/13/2014 229		Henn, Ted	400	Shop Rate	3.00	Hours	6.32	\$18.96
867200	DILLMAN BAG HOUSE	1	02	Labor Burden		03/13/2014 229		Henn, Ted	400	Shop Rate	1.00	Hours	8.60	\$8.60

The Kraemer Company, LLC
 820 Wachter Ave
 P.O. Box 235
 Plain, WI 53577

3/28/2014

Stedman Lime Mill and Greyhawk Cage Mill Chassis, Unit 8671, SN: D-3620 & 1066.

Dillman Reverse Pulse Baghouse, Unit 8672

Superior 24 x 60 Portable Radial Stacking Conveyor, Unit 8702 SN: 530060

		<u>Shop Labor Allocation</u>		
<u>Costs for Stedman Lime Mill, Unit 8671, SN: D-3620</u>				
Invoice from Stedman, Inv # 39769	326,500.00			
Payments made by Kraemer as deposits.				
10/28/2013	113,260.00			
12/23/2013	177,980.00			
1/24/2014	35,260.00			
	<u>326,500.00</u>			
 <u>Costs for Greyhawk Cage Mill Chassis, Unit 8671, SN: 1066</u>				
Invoice from RB Scott, Inv # 0089185-IN	155,400.00	25,593.51	507,493.51	76%
Payment will be paid by Kraemer in April, 2014				
 <u>Costs for Dillman Reverse Pulse Baghouse, Unit 8672</u>				
Invoice from Dillman, Inv # 474604	112,747.00			
Credit Memo for Paint, # 474037	(1,956.24)			
	<u>110,790.76</u>	25,620.40	136,411.16	20%
Payments made by Kraemer as deposits.				
11/18/2013	20,000.00			
2/27/2014	88,750.00			
3/25/2014	2,040.76			
	<u>110,790.76</u>			
 <u>Costs for Superior 24 x 60 Portable Radial Stacking Conveyor, Unit 8702, SN: 530060</u>				
Invoice from RB Scott, Inv # 008862-IN	21,775.00	5,023.40	26,798.40	4%
Payment will be paid by Kraemer in April, 2014				
 <u>Additional Expenses spent in house to get Assets up and going.</u>				
Labor, Labor Burden, Parts, and Supplies	56,237.31	56,237.31		
Please see detail report.				
 Total Amount to be leased:	 <u>670,703.07</u>			



34600 COUNTY HWY. K • PRAIRIE DU CHIEN, WI 53821 USA • PH 608.326.4820 • FAX 608.326.4962

INVOICE

5648

Sold To: 101451
 THE KRAEMER COMPANY, LLC
 820 WACHTER AVENUE
 POST OFFICE BOX 235
 PLAIN WI 53557

THE KRAEMER COMPANY, LLC
 820 WACHTER AVENUE
 PO BOX 235
 PLAIN WI 53577-0235

Invoice: 474604
 Invoice Date: 03/18/2014

Sales Order: 258566
 Packing Slip: 62478

Ship Date: 03/11/2014
 PO Number: Verbal John

F.O.B.: FACTORY

Ship Via To Be Determined Freight

Due Date: 03/18/2014

Terms: CASH BEFORE SHIP

Freight:

Page: 1 of 1

Line	Part Number/Description	Qty Ordered	Qty Shipped	List Price	Net Price	Ext Net Price
1	CFM12000	1.00 EA	1.00 EA	108,650.000	89,794.000	89,794.00
2	Ductwork	1.00 EA	1.00 EA	26,785.000	22,953.000	22,953.00
3	Auger	1.00 EA	1.00 EA	0.000	0.000	0.00

112,747.00 USD

Tax:

→ exempt

6,201.09 USD

Revised JAF

Total: 10,198.09 USD

PLEASE REMIT TO
 Astec, Inc.
 P.O. Box 934331
 Atlanta, GA 31193-4331

PLEASE ADVISE THE CREDIT DEPT OF ANY PROBLEMS IN MAKING PAYMENT WITHIN TERMS. CALL (423) 867-4210

Authorization for the return of any parts must be obtained from the Astec Parts Department or Astec Returns Department before returning. Astec will not be responsible for any items which are returned without an RMA number. All returned parts are subject to a 20% restocking fee. Any shipping charges, customs fees, duties, and taxes, if applicable, are the responsibility of the buyer. No returns will be accepted after 60 days of receipt of shipment. Refunds will not be issued for custom or special order parts. Restocking fees and/or freight charges will not be applicable in the case of defective, incorrect, or damaged merchandise. Final credit is subject to inspection and acceptance of returned material.



INVOICE

34800 COUNTY HWY. K • PRAIRIE DU CHIEN, WI 53821 USA • PH 608.326.4820 • FAX 608.326.4962

Sold To: 101451
THE KRAEMER COMPANY, LLC
820 WACHTER AVENUE
POST OFFICE BOX 235
PLAIN WI 53557

THE KRAEMER COMPANY, LLC
820 WACHTER AVENUE
PO BOX 235
PLAIN WI 53577-0235

Invoice: 474037
Invoice Date: 03/07/2014

Sales Order: 258566
Packing Slip: -

Ship Date: 03/07/2014
PO Number: Verbal John

Ship Via To Be Determined Freight

Due Date: 03/07/2014

Terms: CASH BEFORE SHIP

Freight:

CREDIT MEMO

Page: 1 of 1

Line	Part Number/Description	Qty Ordered	Qty Shipped	List Price	Net Price	Ext Net Price
1	CFM12000	0 EA	-1.00 EA	1,956.240	1,956.240	-1,956.24

Line Ref. 2

Paint Credit for materials Primer/Paint

Total Ordered: -1,956.24 USD

Total: -1,956.24 USD

PLEASE REMIT TO
Astec, Inc.
P.O. Box 934331
Atlanta, GA 31193-4331

PLEASE ADVISE THE CREDIT DEPT OF ANY PROBLEMS IN MAKING PAYMENT WITHIN TERMS. CALL (423) 867-4210

Authorization for the return of any parts must be obtained from the Astec Parts Department or Astec Returns Department before returning. Astec will not be responsible for any items which are returned without an RMA number. All returned parts are subject to a 20% restocking fee. Any shipping charges, customs fees, duties, and taxes, if applicable, are the responsibility of the buyer. No returns will be accepted after 60 days of receipt of shipment. Refunds will not be issued for custom or special order parts. Restocking fees and/or freight charges will not be applicable in the case of defective, incorrect, or damaged merchandise. Final credit is subject to inspection and acceptance of returned material.



Invoice

630-600-3600
630-834-9427 (fax)
chi.sales@mcmaster.com

Purchase Order	209103
Total	\$6.12
Invoice	77527876
Invoice Date	3/17/14
Payment Terms	2% 10, Net 30
Deduct \$0.04 on merchandise if paid by 3/27/14.	

Billed to
KRAEMER CO LLC
820 WACHTER AVE
PLAIN WI 53577

RECEIVED

MAR 21 2014

Shipped to
Kraemer Co LLC
840 Wachter Ave
Plain WI 53577

Mail Payment to
McMaster-Carr
PO Box 7690
Chicago IL 60680-7690

Your Account
138633800

Doug placed this order.

Line	Product	Ordered	Shipped	Balance	Price	Total
1	6214K26 Comfort-Grip Knurled-Rim Knob, 1/4"-20 Threaded Insert, 1-9/16" Diameter	1 Each	1	0	1.81 Each	1.81
Merchandise						1.81
Shipping						4.31
Total						\$6.12

Packing List	Shipped	Weight	Carrier	Tracking
1285667-01	3/17/14	1 lb	Spee-Dee Delivery	1Z0062500383516440

TAX EXEMPT

8672-0-14
pa



CONNEY SAFETY

A DIVISION OF WESCO DISTRIBUTION, INC.

ACCOUNTS RECEIVABLE:
PHONE: 800-532-1860
FAX: 800-854-7932
conney.com

PAGE 1

INVOICE

1139
S
H
I
P
T
O
M
A
I
L
T
O

3202 Latham Drive PO Box 44575 Madison, WI 53744-4575
THE KRAEMER COMPANY LLC
ATTN: MIKE ANLIKER
840 WACHTER AVE
PLAIN WI 53977

INVOICE NUMBER: 04642260
INVOICE DATE: 3/13/14
CUSTOMER NUMBER: 100023543
P.O. NUMBER: 511021
ORDERED BY: MIKE ANLIKER
TERMS: Net 60 days

THE KRAEMER COMPANY LLC
PO BOX 235
PLAIN WI 53577

DATE ENTERED: 3/13/14
E.O.B. :
SHIPPED VIA: UPSGD
ORDER NUMBER: W5905/01
TERRITORY: 582
SHIPPING DATE: 3/13/14

RECEIVED
MAR 17 2014

BY:

ITEM NUMBER	UNIT	DESCRIPTION	SIZE, COLOR STYLE OR PACK	QUANTITIES			UNIT PRICE	AMOUNT
				ORDERED	B.O.	SHIPPED		
173720	PK	LBL DNGR 110 VOLTS 3.5X5	56 LELC	2		2	13.78	27.56
33181	PK	LBL DNGR 220 VOLTS 56	3.5X5 LELC	2		2	10.60	21.60
64726VS	EA	SGN DGR NO SMOKNG MATCH OPEN VY	7X10 MSMK	10		10	8.21	82.10
64909VS	EA	SGN DGR HEARING PROTCTN RQ W/S VY PROMO APPLIED	7X10 NPPE	10		10	8.21	82.10

GSA CONTRACT INFORMATION AND TERMS AND CONDITIONS ARE ON REVERSE SIDE
MATERIAL SAFETY DATA SHEETS ARE AVAILABLE UPON REQUEST

Merchandise: 213.36
Tax: 11.75 ✓
Shipping and Handling:
Subtotal: 225.11
Pre-paid:

SATISFACTION GUARANTEED
THANK YOU FOR YOUR ORDER

USD 225.11

REMITTANCE DOCUMENT TO INSURE PROPER CREDIT, PLEASE DETACH THIS PORTION AND RETURN WITH REMITTANCE.

B
I
L
L
T
O

THE KRAEMER COMPANY LLC
PO BOX 235
PLAIN WI 53577

COMPANY: 1

CUSTOMER NUMBER: 100023543

R
E
M
I
T
T
O

CONNEY SAFETY
P O BOX 44575
MADISON WI 53744-4575

INVOICE NUMBER: 04642260

INVOICE DATE: 3/13/14

AMOUNT DUE: 225.11

Machine Control Specialists ¹⁴⁰⁰

820-B Moasis Drive
P.O. Box 205
Little Chute, WI 54140
920-788-8052
dan.steiner@mccontrol.com

Invoice

DATE	INVOICE #
2/26/2014	3629

BILL TO
Kraemer Company 820 Wachter Avenue P.O. Box 235 Plain, WI 53577

SHIP TO
Kraemer Company 820 Wachter Avenue P.O. Box 235 Plain, WI 53577
 BY: _____

P.O. NUMBER	TERMS	DUE DATE	SHIP	VIA	F.O.B.	PROJECT
209051	Net 30	3/28/2014	2/24/2014	US Special		3633
QUANTITY	ITEM CODE	DESCRIPTION			PRICE EACH	AMOUNT
1	Fabrication	Control Panel for 1) 60HP Fan, 3) 5HP Augers, 1) 10HP Auger and 1) Warning Alarm Unit# 8672			9,850.00	9,850.00
1	Freight	SHIPPING CHARGES			155.33	155.33
<p><i>8672-10-14</i> <i>17c</i></p> <p>TAX EXEMPT</p>						
Thank you for your business.					Total	\$10,005.33

Service charge will be assessed to all past due amounts at the rate of 1.5% per month



AUTO PARTS

Great people, great products, great prices!

PETERSON'S AUTO PARTS 1510
505 WATER STREET
SAUK CITY, WI 53583
608-643-3329

PAGE 1 OF 2
REF# 138099

RIGHT PLACE, RIGHT PARTS, RIGHT PRICE!



21201401280558600001138040000138099280

ANY PRODUCT RETURNED FOR CREDIT MUST BE ACCOMPANIED BY THIS RECEIPT.

SEE CARQUEST STORE FOR DETAILS OF THE COAST TO COAST GUARANTEE.

KRAEMER COMPANY, LLC
820 WACHTER AVE/P O BOX 235
PLAIN, WI 53577-0235

THE KRAEMER COMPANY LLC
WM. J. KRAEMER/JOSEPH KRAEMER

INVOICE NO.	CUSTOMER NO.	DATE	CUST. P.O. NO.		SALES ID	TEAMMATE ID	FORM OF PYMT.	
5586-113804	3965	01/28/14	209004		SALES	GREG	CHARGE	
MFG. PART NUMBER	ORDERED	SHIPPED	LIST PRICE	NET	NET CORE	EXT. AMOUNT	TAX	
1 DIC RHD-S5 IMRON 3.5 HG+ HIGH GLOSS MIX	8	8	1132.18	679.31	0.00	5434.48	N/N	
2 DIC 9T00A-01 ACTIVATOR HC64	8	8	299.43	179.66	0.00	1437.28	N/N	
3 DIC LF-63325P-05 2.1 ST SHALE GRAY HC61	4	4	597.18	358.31	0.00	1433.24	N/N	
4 DIC VF-525-05 2.1 ST ACTIVATOR HC63	4	4	600.48	360.29	0.00	1441.16	N/N	
5 DIC Y32035-01 DUPONT THINNER HC63	5	5	48.15	28.89	0.00	144.45	N/N	

WARRANTY DISCLAIMER: The manufacturer's warranty, if any, constitutes the only warranty with respect to the sale of all goods. SELLER HEREBY EXPRESSLY DISCLAIMS ALL WARRANTIES, EITHER EXPRESSED OR IMPLIED, INCLUDING ANY IMPLIED WARRANTY OF MERCHANTABILITY OR FITNESS FOR A PARTICULAR PURPOSE. Seller does not authorize any person to grant any warranty or assume any liability by Seller.

SHIP VIA	DELV. TIME	DELV. ID	FREIGHT	TAXABLE AMT.	SALES TAX	TOTAL CORE	PREV. DEPOSIT
09:55 AM	RECEIVED BY X					PAY THIS AMOUNT	CONTINUED

Great people, great products, great prices!™



AUTO PARTS

PETERSON'S AUTO PARTS
505 WATER STREET
SAUK CITY, WI 53583
608-643-3329

PAGE 2 OF 2
REF# 138099

RIGHT PLACE, RIGHT PARTS, RIGHT PRICE!



21201401280558600001138040000138099280

ANY PRODUCT RETURNED FOR CREDIT MUST BE ACCOMPANIED BY THIS RECEIPT.

SEE CARQUEST STORE FOR DETAILS OF THE COAST TO COAST GUARANTEE.

KRAEMER COMPANY, LLC
820 WACHTER AVE/P O BOX 235
PLAIN, WI 53577-0235

THE KRAEMER COMPANY LLC
WM. J. KRAEMER/JOSEPH KRAEMER

INVOICE NO.	CUSTOMER NO.	DATE	CUST. P.O. NO.		SALES ID	TEAMMATE ID	FORM OF PYMT.	
5586-113804	3965	01/28/14	209004		SALES	GREG	CHARGE	
MFG. PART NUMBER	ORDERED	SHIPPED	LIST PRICE	NET	NET CORE	EXT. AMOUNT	TAX	
6 DIC 9M01-01 IND STRENGTH THIN HC61	4	4	98.58	59.15	0.00	236.60	N/N	
8672-10-17 DC								
TAX EXEMPT								

WARRANTY DISCLAIMER: The manufacturer's warranty, if any, constitutes the only warranty with respect to the sale of all goods. SELLER HEREBY EXPRESSLY DISCLAIMS ALL WARRANTIES, EITHER EXPRESSED OR IMPLIED, INCLUDING ANY IMPLIED WARRANTY OF MERCHANTABILITY OR FITNESS FOR A PARTICULAR PURPOSE. Seller does not authorize any person to grant any warranty or assume any liability by Seller.

SHIP VIA	DELV. TIME	DELV. ID	FREIGHT	TAXABLE AMT.	SALES TAX	TOTAL CORE	PREV. DEPOSIT
09:55 AM	RECEIVED BY X			0.00	0.00	PAY THIS AMOUNT	10127.21



March 17, 2015

Brian Kennedy (LR-8J)
RCRA Branch
U.S. EPA, Region 5
77 West Jackson Blvd.
Chicago, IL 60604

RE: In the Matter of The Kraemer Company, LLC
U.S. EPA ID #: WIR000117010
Docket No: RCRA-05-2015-007
Respondent: The Kraemer Company, LLC

Dear Brian:

As required under the Consent Agreement and Final Order (“CAFO”) executed by the parties in the above-referenced matter, please find The Kraemer Company, LLC’s First SEP Report (“SEP Report”) enclosed with this letter. The enclosed SEP Report addresses the requirements of Paragraph 69 of the CAFO by including:

- a. A detailed description of the installation of the Dillman Reverse Pulse Baghouse, Unit 8672;
- b. Itemized costs of goods and services used to complete the installation of the Dillman Reverse Pulse Baghouse, Unit 8672 documented by copies of invoices, purchase orders, or canceled checks that specifically identify and itemize the individual costs of the goods and services; and
- c. A Certification that The Kraemer Company, LLC has completed the installation of the Dillman Reverse Pulse Baghouse, Unit 8672 in compliance with this CAFO by a responsible corporate officer.

please feel free to reach out to Attorney Buck Sweeney if you have any questions or comments regarding the foregoing.

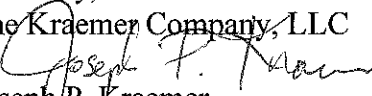
Sincerely,
The Kraemer Company, LLC

Joseph P. Kraemer
Vice President

Enc.

FIRST SEP REPORT CERTIFICATION

I certify that I am familiar with the information in this document and that, based on my inquiry of those individuals responsible for obtaining the information, it is true and complete to the best of my knowledge. I know that there are significant penalties for submitting false information, including the possibility of fines and imprisonment for knowing violations.

By: Joseph P. Kraemer
Name: JOSEPH P. KRAEMER
Title: VICE PRESIDENT
Date: 3/17/15

COMPLETION INITIAL INSTALLATION CERTIFICATION

I certify that The Kraemer Company, LLC has completed the initial installation of the Dillman Reverse Pulse Baghouse, Unit 8672 in compliance with this CAFO.

By: Joseph P. Kraemer
Name: JOSEPH P. KRAEMER
Title: VICE PRESIDENT
Date: 3/17/15



March 16, 2015

Mr. Brian Kennedy
U.S. EPA Region 5
77 West Jackson Blvd.
Chicago, IL 60604

RE: Docket No: RCRA-05-2015-0007
Description of Installation of Dillman Baghouse, Unit 8672

Mr. Kennedy,

The Dillman Reverse Pulse Baghouse, Unit 8672, is being used in connection with our Greyhawk Cage Mill Chassis, Unit 8671. The "Baghouse" is collecting the fine particles generated by the "Mill" to prevent them from being directly discharged into the air. The Baghouse is a separate unit on its own chassis that sets along the side of the Mill. The fine particulates created by the Mill are discharged through a closed conveyor system with one section cut open and a sealed knockout box placed over the top of this opening. This knockout box has a 24" opening with sealed ductwork and connections mounted to allow the transfer of the fine particles into the Baghouse. The Baghouse fan creates the suction that moves the fine particulate from the discharge of the Mill to the Baghouse. This fine particulate is collected in a series of bags inside the Baghouse. The Dillman Reverse Pulse process utilizes an air nozzle that is timed to pulse air into a row of bags to dislodge the fine particulate from the bags. This air nozzle moves from row to row through a series of fast acting doors to continuously dislodge the fine particulate from the bags. Once this material is released from the bags it is dropped to the floor of the Baghouse and collected by two augers on each side which transfers the material to a third auger that runs perpendicular and moves the material out of the Baghouse. The fine material is either blended back into the finished product by directly discharging it on the finished material conveyor belt or removed from the side of the Baghouse with a loader and added back into the finished material pile. The Baghouse will operate in conjunction with the Mill in accordance with the manufacturers specifications. Our Lime Mill Plant, which includes these two units along with others, is portable, and will be moved to numerous locations throughout the year. Each time we move the "Plant" the Baghouse and Mill will be disconnected and reconnected at the next location. The Plant, with the Baghouse was put into production in March of 2014. The Plant operation is seasonal and was not working through the winter. The Plant will be setup to run in March 2015.

Sincerely,
The Kraemer Company, LLC

Joseph P. Kraemer
Vice President

Enc.

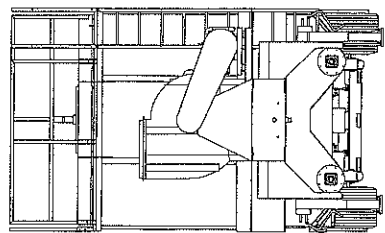
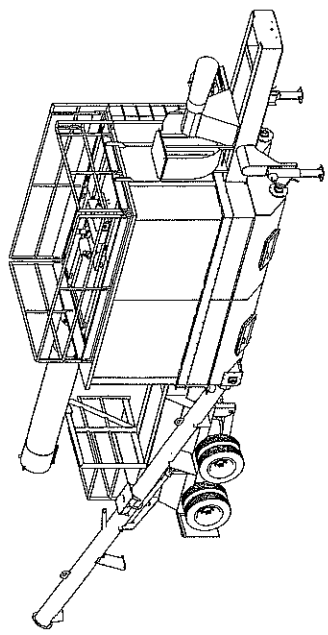
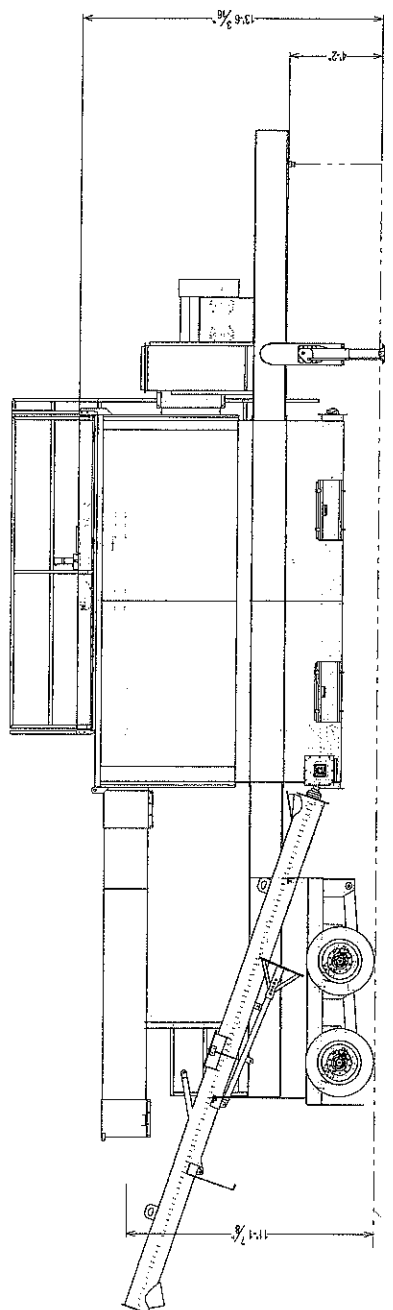
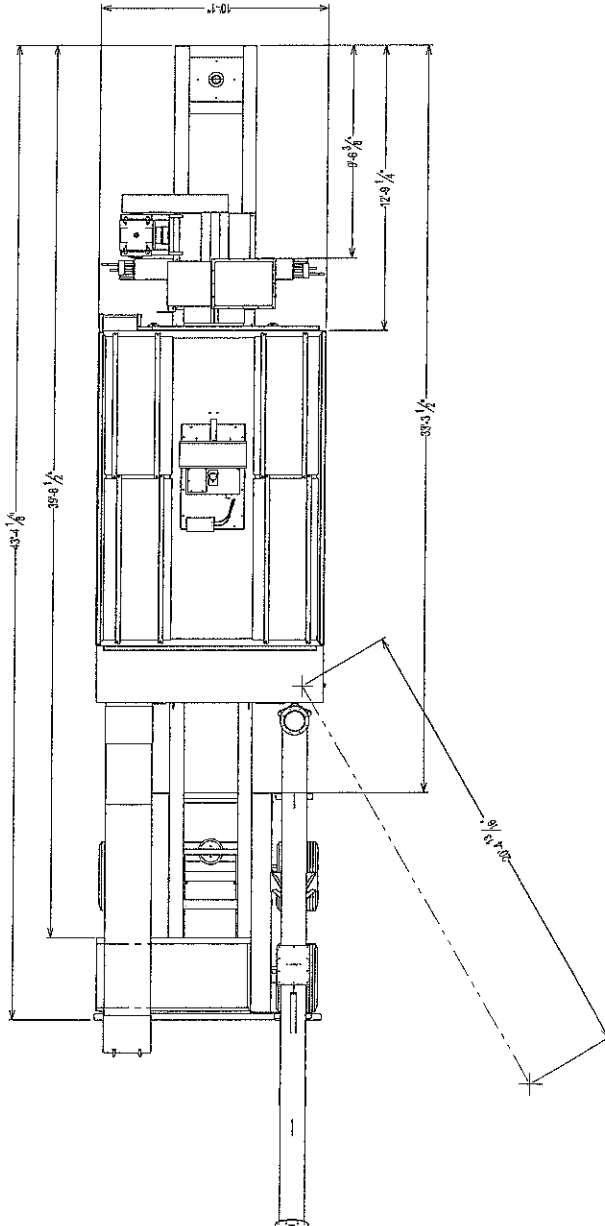

DILLMAN
 3400 CHERRY STREET, CHICAGO, IL 60641
 RELIABLE EQUIPMENT

Part Name: SINGLE MOTOR BACKHOUSE
 Drawing: 314000001
 Scale: 1:1
 Date: 11/24/84
 Author: [blank]
 Checker: [blank]
 Title: [blank]

TOLERANCE NOTE:
 UNLESS OTHERWISE SPECIFIED, DIMENSIONS ON THIS DRAWING ARE:
 FRACTIONS TO THE NEAREST 1/32 INCH
 DECIMALS TO THE NEAREST 0.005 INCH
 ANGLES TO THE NEAREST 5 MINUTES
 THE DRAWING AND THE DESIGN SHOWS THE DESIGN PROPERTY OF ABE, INC.
 AND USE OR COPIES THEREOF CANNOT BE MADE WITHOUT WRITTEN CONSENT.

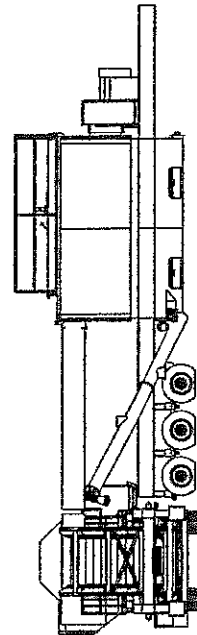
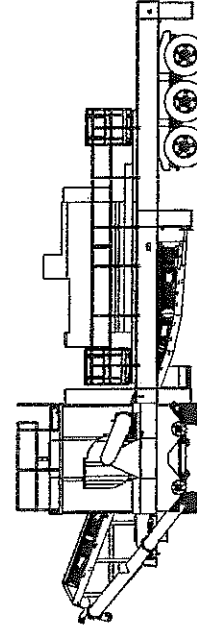
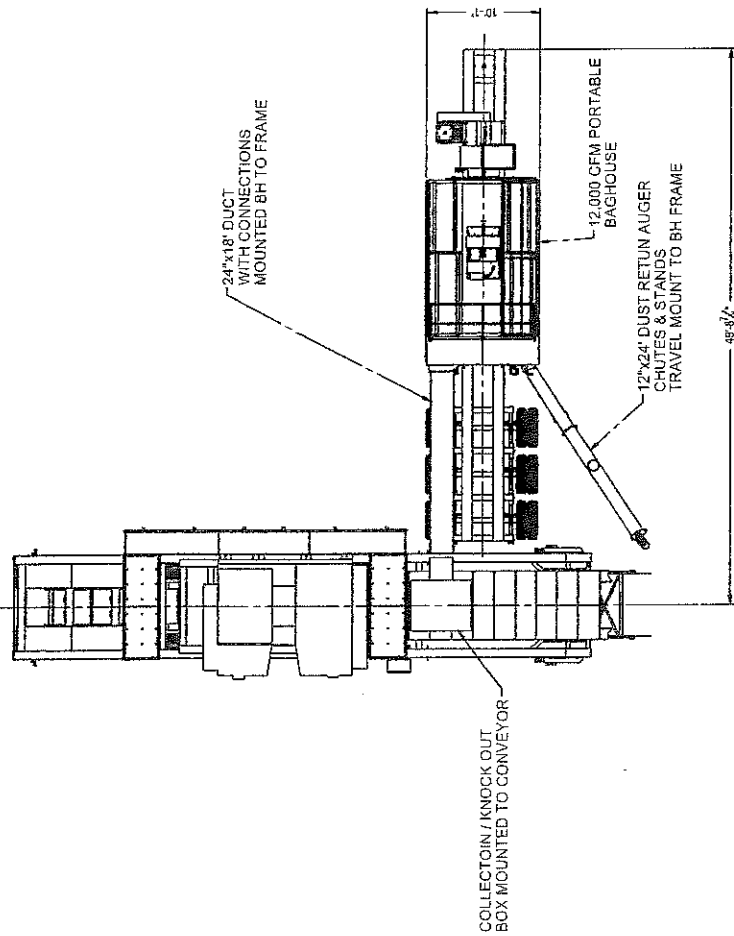
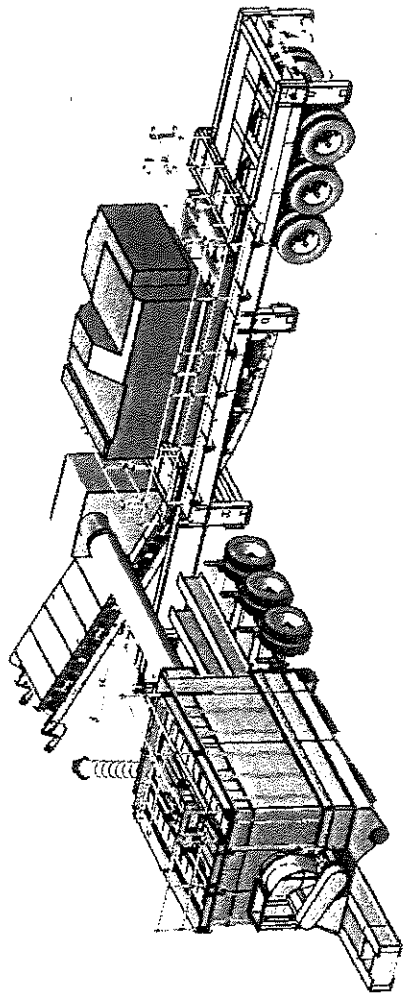

DILLMAN	
10000 1st Street, P.O. Box 1000, W. Des Moines, IA 50319	
TEL: 515/281-1111 FAX: 515/281-1112	
E-MAIL: SALES@DILLMAN.COM	
WWW.DILLMAN.COM	
DILLMAN PORTABLE BAGHOUSE	
DATE	10/10/00
BY	10/10/00
CHKD BY	10/10/00
APP'D BY	10/10/00
REV	10/10/00
48'-8 1/2" 70274-LAYOUT 00	

THIS DRAWING IS FOR INFORMATION ONLY. THE USER SHALL BE RESPONSIBLE FOR OBTAINING ALL NECESSARY PERMITS AND REGULATIONS. THE USER SHALL BE RESPONSIBLE FOR OBTAINING ALL NECESSARY PERMITS AND REGULATIONS. THE USER SHALL BE RESPONSIBLE FOR OBTAINING ALL NECESSARY PERMITS AND REGULATIONS.

Copyright © 2000 Dillman Corporation. All rights reserved.

Work Order Cost Detail Report

Equipment	Equipment Description	Work Order	CT	Cost Type Description	Date	Ref. 1	Ref. 1 Description	Ref. 2	Ref. 2 Description	Quantity	UOM	Unit Cost	Amount
867200	DILLMAN BAG HOUSE	1	01	Labor	03/21/2014 229		Henn, Ted	400	Shop Rate	3.00	Hours	26.40	\$79.20
867200	DILLMAN BAG HOUSE	1	01	Labor	03/20/2014 229		Henn, Ted	440	Ted Henn T/C Rate	4.50	Hours	27.40	\$123.30
867200	DILLMAN BAG HOUSE	1	01	Labor	03/20/2014 229		Henn, Ted	440	Ted Henn T/C Rate	1.00	Hours	41.10	\$41.10
867200	DILLMAN BAG HOUSE	1	01	Labor	03/20/2014 229		Henn, Ted	400	Shop Rate	3.50	Hours	39.60	\$138.60
867200	DILLMAN BAG HOUSE	1	01	Labor	03/19/2014 229		Henn, Ted	440	Ted Henn T/C Rate	1.00	Hours	27.40	\$27.40
867200	DILLMAN BAG HOUSE	1	01	Labor	03/19/2014 229		Henn, Ted	440	Ted Henn T/C Rate	2.00	Hours	41.10	\$82.20
867200	DILLMAN BAG HOUSE	1	01	Labor	03/18/2014 229		Henn, Ted	400	Shop Rate	8.00	Hours	26.40	\$211.20
867200	DILLMAN BAG HOUSE	1	01	Labor	03/18/2014 229		Henn, Ted	400	Shop Rate	1.00	Hours	39.60	\$39.60
867200	DILLMAN BAG HOUSE	1	01	Labor	03/18/2014 269		Ruhland, Steven	442	Steve Ruhland T/C Rate	1.00	Hours	42.75	\$42.75
867200	DILLMAN BAG HOUSE	1	01	Labor	03/17/2014 229		Henn, Ted	400	Shop Rate	8.00	Hours	26.40	\$211.20
867200	DILLMAN BAG HOUSE	1	01	Labor	03/17/2014 229		Henn, Ted	400	Shop Rate	1.00	Hours	39.60	\$39.60
867200	DILLMAN BAG HOUSE	1	01	Labor	03/14/2014 211		Bindl, Daniel	400	Shop Rate	8.00	Hours	19.97	\$159.76
867200	DILLMAN BAG HOUSE	1	01	Labor	03/14/2014 211		Bindl, Daniel	400	Shop Rate	1.00	Hours	29.96	\$29.96
867200	DILLMAN BAG HOUSE	1	01	Labor	03/14/2014 228		Gruber, Eric	400	Shop Rate	8.00	Hours	17.33	\$138.64
867200	DILLMAN BAG HOUSE	1	01	Labor	03/14/2014 228		Gruber, Eric	400	Shop Rate	1.00	Hours	25.99	\$25.99
867200	DILLMAN BAG HOUSE	1	01	Labor	03/14/2014 229		Henn, Ted	400	Shop Rate	5.00	Hours	26.40	\$132.00
867200	DILLMAN BAG HOUSE	1	01	Labor	03/14/2014 229		Henn, Ted	400	Shop Rate	1.00	Hours	39.60	\$39.60
867200	DILLMAN BAG HOUSE	1	01	Labor	03/14/2014 269		Ruhland, Steven	420	Steven Ruhland-Shop Rate	3.00	Hours	27.50	\$82.50
867200	DILLMAN BAG HOUSE	1	01	Labor	03/14/2014 272		Richards, Randy	400	Shop Rate	8.00	Hours	25.38	\$203.04
867200	DILLMAN BAG HOUSE	1	01	Labor	03/14/2014 272		Richards, Randy	400	Shop Rate	1.00	Hours	38.07	\$38.07
867200	DILLMAN BAG HOUSE	1	01	Labor	03/13/2014 211		Bindl, Daniel	400	Shop Rate	1.00	Hours	29.95	\$29.95
867200	DILLMAN BAG HOUSE	1	01	Labor	03/13/2014 228		Gruber, Eric	400	Shop Rate	3.00	Hours	17.33	\$51.99
867200	DILLMAN BAG HOUSE	1	01	Labor	03/13/2014 229		Henn, Ted	400	Shop Rate	3.00	Hours	26.40	\$79.20
867200	DILLMAN BAG HOUSE	1	01	Labor	03/13/2014 229		Henn, Ted	400	Shop Rate	1.00	Hours	39.60	\$39.60
867200	DILLMAN BAG HOUSE	1	01	Labor	03/13/2014 272		Richards, Randy	400	Shop Rate	1.50	Hours	38.07	\$57.11
867200	DILLMAN BAG HOUSE	1	01	Labor	03/06/2014 269		Ruhland, Steven	420	Steven Ruhland-Shop Rate	5.00	Hours	27.50	\$137.50
867200	DILLMAN BAG HOUSE	1	01	Labor Burden	03/21/2014 229		Henn, Ted		Shop Rate	84.50	Hours		\$2,281.06
867200	DILLMAN BAG HOUSE	1	02	Labor Burden	03/20/2014 229		Henn, Ted	400	Shop Rate	3.00	Hours	6.29	\$18.88
867200	DILLMAN BAG HOUSE	1	02	Labor Burden	03/20/2014 229		Henn, Ted	440	Ted Henn T/C Rate	4.50	Hours	6.53	\$29.38
867200	DILLMAN BAG HOUSE	1	02	Labor Burden	03/20/2014 229		Henn, Ted	440	Ted Henn T/C Rate	1.00	Hours	8.89	\$8.89
867200	DILLMAN BAG HOUSE	1	02	Labor Burden	03/20/2014 229		Henn, Ted	400	Shop Rate	3.50	Hours	8.56	\$29.97
867200	DILLMAN BAG HOUSE	1	02	Labor Burden	03/19/2014 229		Henn, Ted	440	Ted Henn T/C Rate	1.00	Hours	6.53	\$6.53
867200	DILLMAN BAG HOUSE	1	02	Labor Burden	03/19/2014 229		Henn, Ted	440	Ted Henn T/C Rate	2.00	Hours	8.89	\$17.78
867200	DILLMAN BAG HOUSE	1	02	Labor Burden	03/18/2014 229		Henn, Ted	400	Shop Rate	8.00	Hours	6.29	\$50.32
867200	DILLMAN BAG HOUSE	1	02	Labor Burden	03/18/2014 229		Henn, Ted	400	Shop Rate	1.00	Hours	8.56	\$8.56
867200	DILLMAN BAG HOUSE	1	02	Labor Burden	03/18/2014 269		Ruhland, Steven	442	Steve Ruhland T/C Rate	1.00	Hours	9.42	\$9.42
867200	DILLMAN BAG HOUSE	1	02	Labor Burden	03/17/2014 229		Henn, Ted	400	Shop Rate	8.00	Hours	6.29	\$50.32
867200	DILLMAN BAG HOUSE	1	02	Labor Burden	03/17/2014 229		Henn, Ted	400	Shop Rate	1.00	Hours	8.56	\$8.56
867200	DILLMAN BAG HOUSE	1	02	Labor Burden	03/14/2014 211		Bindl, Daniel	400	Shop Rate	8.00	Hours	4.93	\$39.47
867200	DILLMAN BAG HOUSE	1	02	Labor Burden	03/14/2014 211		Bindl, Daniel	400	Shop Rate	1.00	Hours	6.73	\$6.73
867200	DILLMAN BAG HOUSE	1	02	Labor Burden	03/14/2014 228		Gruber, Eric	400	Shop Rate	8.00	Hours	4.00	\$31.99
867200	DILLMAN BAG HOUSE	1	02	Labor Burden	03/14/2014 228		Gruber, Eric	400	Shop Rate	1.00	Hours	5.42	\$5.42
867200	DILLMAN BAG HOUSE	1	02	Labor Burden	03/14/2014 229		Henn, Ted	400	Shop Rate	5.00	Hours	6.32	\$31.58
867200	DILLMAN BAG HOUSE	1	02	Labor Burden	03/14/2014 229		Henn, Ted	400	Shop Rate	1.00	Hours	8.67	\$8.67
867200	DILLMAN BAG HOUSE	1	02	Labor Burden	03/14/2014 269		Ruhland, Steven	420	Steven Ruhland-Shop Rate	3.00	Hours	6.57	\$19.72
867200	DILLMAN BAG HOUSE	1	02	Labor Burden	03/14/2014 272		Richards, Randy	400	Shop Rate	8.00	Hours	6.42	\$51.32
867200	DILLMAN BAG HOUSE	1	02	Labor Burden	03/14/2014 272		Richards, Randy	400	Shop Rate	1.00	Hours	8.77	\$8.77
867200	DILLMAN BAG HOUSE	1	02	Labor Burden	03/13/2014 211		Bindl, Daniel	400	Shop Rate	1.00	Hours	6.75	\$6.75
867200	DILLMAN BAG HOUSE	1	02	Labor Burden	03/13/2014 228		Gruber, Eric	400	Shop Rate	3.00	Hours	4.00	\$12.00
867200	DILLMAN BAG HOUSE	1	02	Labor Burden	03/13/2014 229		Henn, Ted	400	Shop Rate	3.00	Hours	6.32	\$18.96
867200	DILLMAN BAG HOUSE	1	02	Labor Burden	03/13/2014 229		Henn, Ted	400	Shop Rate	1.00	Hours	8.60	\$8.60

Work Order Cost Detail Report

Equipment	Equipment Description	Work Order	CT	Cost Type Description	Date	Ref. 1	Ref. 1 Description	Ref. 2	Ref. 2 Description	Quantity	UOM	Unit Cost	Amount
867200	DILLMAN BAG HOUSE	1	02	Labor Burden	03/13/2014	272	Richards, Randy	400	Shop Rate	1.50	Hours	8.79	\$13.19
867200	DILLMAN BAG HOUSE	1	02	Labor Burden	03/06/2014	269	Ruhland, Steven	420	Steven Ruhland-Shop Rate	5.00	Hours	6.55	\$32.76
867200	DILLMAN BAG HOUSE	1	02	Labor Burden	03/17/2014	1	Parts Department	2540080	ELECTRICAL CORD 10/3	84.50			\$534.54
867200	DILLMAN BAG HOUSE	1	14	Parts Exp - Eq	03/17/2014	1	Parts Department	77527876		6.00	FT	0.89	\$5.34
867200	DILLMAN BAG HOUSE	1	14	Parts Exp - Eq	03/17/2014	1420	McMaster-Carr Supply Co.			0.00			\$6.12
867200	DILLMAN BAG HOUSE	1	14	Parts Exp - Eq	03/14/2014	1	Parts Department	3342480	BUSH RED 3 TO 2	1.00	EA	13.13	\$13.13
867200	DILLMAN BAG HOUSE	1	14	Parts Exp - Eq	03/13/2014	1139	Conney Safety Products, L	4642260		0.00			\$225.11
867200	DILLMAN BAG HOUSE	1	14	Supplies Exp - Eq	03/17/2014	1	Parts Department	7003800	OVERSIZE LOAD 18"X84"	7.00			\$249.70
867200	DILLMAN BAG HOUSE	1	17	Supplies Exp - Eq	03/17/2014	1	Parts Department	7000800	GLOVE TIG WELDING 1350L	2.00	EA	66.60	\$133.20
867200	DILLMAN BAG HOUSE	1	17	Supplies Exp - Eq	03/17/2014	1	Parts Department	8521100	STRIKER RAD64003412	2.00	EA	9.17	\$18.34
867200	DILLMAN BAG HOUSE	1	17	Supplies Exp - Eq	03/17/2014	1	Parts Department			1.00	EA	1.65	\$1.65
867200	DILLMAN BAG HOUSE	1	17							5.00			\$153.19
867200	DILLMAN BAG HOUSE	1								181.00			\$3,218.49
867200	DILLMAN BAG HOUSE	10	01	Labor	03/17/2014	206	Bindl, Kenneth	421	Kenneth Bindl-Shop Rate	6.00	Hours	23.79	\$142.74
867200	DILLMAN BAG HOUSE	10	01	Labor	03/17/2014	206	Bindl, Kenneth	421	Kenneth Bindl-Shop Rate	6.00	Hours	5.78	\$34.70
867200	DILLMAN BAG HOUSE	10	02	Labor Burden	03/17/2014	206	Bindl, Kenneth	421	Kenneth Bindl-Shop Rate	6.00	Hours	5.78	\$34.70
867200	DILLMAN BAG HOUSE	10	02	Labor Burden	03/17/2014	206	Bindl, Kenneth	421	Kenneth Bindl-Shop Rate	6.00	Hours	5.78	\$34.70
867200	DILLMAN BAG HOUSE	10	14	Parts Exp - Eq	03/28/2014	1	Parts Department	2540100	ELECTRICAL CORD 2/0	100.00	FT	17.62	\$1,762.00
867200	DILLMAN BAG HOUSE	10	14	Parts Exp - Eq	03/28/2014	1	Parts Department	2540130	ELECTRIC CORD 10/4	95.00	FT	1.41	\$133.95
867200	DILLMAN BAG HOUSE	10	14	Parts Exp - Eq	03/28/2014	1	Parts Department	7710020	PLATE-CQ 10GA	50.00	SF	3.39	\$169.50
867200	DILLMAN BAG HOUSE	10	14	Parts Exp - Eq	02/26/2014	1400	Machine Control Specialis	3629	CONTROL PANEL	0.00			\$10,005.33
867200	DILLMAN BAG HOUSE	10	14	Parts Exp - Eq	01/28/2014	1510	Peterson Auto Parts	5586-113804		0.00			\$10,127.21
867200	DILLMAN BAG HOUSE	10	14	Supplies Exp - Eq	03/18/2014	1	Parts Department	4092200	RATCHET STRAP 1" 8840T1/4	247.00			\$22,197.99
867200	DILLMAN BAG HOUSE	10	17	Supplies Exp - Eq	03/18/2014	1	Parts Department	4092200	RATCHET STRAP 1" 8840T1/4	2.00	EA	13.24	\$26.48
867200	DILLMAN BAG HOUSE	10	17							2.00			\$26.48
867200	DILLMAN BAG HOUSE	10								261.00			\$22,401.91
867200	DILLMAN BAG HOUSE	10								442.00			\$25,620.40

Work order total
 \$25,620.40

Dillman Reverse Pulse Baghouse, unit 8672
 \$112,747.00
 Dillman Reverse Pulse Baghouse, unit 8672, credit for paint
 (\$1,956.24)
 Baghouse research, consulting, design, installation, inspection, training, compliance, permitting & travel associated expenses
 \$35,478.84
 Grand Total
 \$171,890.00

The Kraemer Company, LLC
 820 Wachter Ave
 P.O. Box 235
 Plain, WI 53577

3/28/2014

Stedman Lime Mill and Greyhawk Cage Mill Chassis, Unit 8671, SN: D-3620 & 1066.

Dillman Reverse Pulse Baghouse, Unit 8672

Superior 24 x 60 Portable Radial Stacking Conveyor, Unit 8702 SN: 530060

		<u>Shop Labor Allocation</u>		
<u>Costs for Stedman Lime Mill, Unit 8671, SN: D-3620</u>				
Invoice from Stedman, Inv # 39769	326,500.00			
Payments made by Kraemer as deposits.				
10/28/2013	113,260.00			
12/23/2013	177,980.00			
1/24/2014	35,260.00			
	<u>326,500.00</u>			
 <u>Costs for Greyhawk Cage Mill Chassis, Unit 8671, SN: 1066</u>				
Invoice from RB Scott, Inv # 0089185-IN	155,400.00	25,593.51	507,493.51	76%
Payment will be paid by Kraemer in April, 2014				
 <u>Costs for Dillman Reverse Pulse Baghouse, Unit 8672</u>				
Invoice from Dillman, Inv # 474604	112,747.00			
Credit Memo for Paint, # 474037	(1,956.24)			
	<u>110,790.76</u>	25,620.40	136,411.16	20%
Payments made by Kraemer as deposits.				
11/18/2013	20,000.00			
2/27/2014	88,750.00			
3/25/2014	2,040.76			
	<u>110,790.76</u>			
 <u>Costs for Superior 24 x 60 Portable Radial Stacking Conveyor, Unit 8702, SN: 530060</u>				
Invoice from RB Scott, Inv # 008862-IN	21,775.00	5,023.40	26,798.40	4%
Payment will be paid by Kraemer in April, 2014				
 <u>Additional Expenses spent in house to get Assets up and going.</u>				
Labor, Labor Burden, Parts, and Supplies	56,237.31	56,237.31		
Please see detail report.				
 Total Amount to be leased:		<u>670,703.07</u>		



INVOICE

34600 COUNTY HWY. K • PRAIRIE DU CHIEN, WI 53821 USA • PH 608.326.4820 • FAX 608.326.4962

5648

Sold To: 101451
 THE KRAEMER COMPANY, LLC
 820 WACHTER AVENUE
 POST OFFICE BOX 235
 PLAIN WI 53557

THE KRAEMER COMPANY, LLC
 820 WACHTER AVENUE
 PO BOX 235
 PLAIN WI 53577-0235

Invoice: 474604
 Invoice Date: 03/18/2014

Sales Order: 258566
 Packing Slip: 62478

Ship Date: 03/11/2014
 PO Number: Verbal John

F.O.B.: FACTORY

Ship Via To Be Determined Freight

Due Date: 03/18/2014

Terms: CASH BEFORE SHIP

Freight:

Page: 1 of 1

Line	Part Number/Description	Qty Ordered	Qty Shipped	List Price	Net Price	Ext Net Price
1	CFM12000	1.00 EA	1.00 EA	108,650.000	89,794.000	89,794.00
2	Ductwork	1.00 EA	1.00 EA	26,785.000	22,953.000	22,953.00
3	Auger	1.00 EA	1.00 EA	0.000	0.000	0.00

112,747.00 USD

Tax:

6,201.09 USD

*Revised
TAX*

*→
exempt*

Total: 10,198.09 USD

PLEASE REMIT TO

Astec, Inc.
 P.O. Box 934331
 Atlanta, GA 31193-4331

PLEASE ADVISE THE CREDIT DEPT OF ANY PROBLEMS IN MAKING PAYMENT WITHIN TERMS. CALL (423) 867-4210

Authorization for the return of any parts must be obtained from the Astec Parts Department or Astec Returns Department before returning. Astec will not be responsible for any items which are returned without an RMA number. All returned parts are subject to a 20% restocking fee. Any shipping charges, customs fees, duties, and taxes, if applicable, are the responsibility of the buyer. No returns will be accepted after 60 days of receipt of shipment. Refunds will not be issued for custom or special order parts. Restocking fees and/or freight charges will not be applicable in the case of defective, incorrect, or damaged merchandise. Final credit is subject to inspection and acceptance of returned material.



34800 COUNTY HWY. K • PRAIRIE DU CHIEN, WI 53821 USA • PH 608.328.4820 • FAX 608.328.4962

INVOICE

Sold To: 101451
THE KRAEMER COMPANY, LLC
820 WACHTER AVENUE
POST OFFICE BOX 235
PLAIN WI 53557

THE KRAEMER COMPANY, LLC
820 WACHTER AVENUE
PO BOX 235
PLAIN WI 53577-0235

Invoice: 474037
Invoice Date: 03/07/2014

Sales Order: 258566
Packing Slip: -

Ship Date: 03/07/2014
PO Number: Verbal John

Ship Via: To Be Determined Freight

Due Date: 03/07/2014

Terms: CASH BEFORE SHIP

Freight:

CREDIT MEMO

Page: 1 of 1

Line	Part Number/Description	Qty Ordered	Qty Shipped	List Price	Net Price	Ext Net Price
1	CFM12000	0 EA	-1.00 EA	1,956.240	1,956.240	-1,956.24

Line Ref. 2

Paint Credit for materials Primer/Paint

Total Ordered: -1,956.24 USD

Total: -1,956.24 USD

PLEASE REMIT TO
Astec, Inc.
P.O. Box 934331
Atlanta, GA 31193-4331

PLEASE ADVISE THE CREDIT DEPT OF ANY PROBLEMS IN MAKING PAYMENT WITHIN TERMS. CALL (423) 867-4210

Authorization for the return of any parts must be obtained from the Astec Parts Department or Astec Returns Department before returning. Astec will not be responsible for any items which are returned without an RMA number. All returned parts are subject to a 20% restocking fee. Any shipping charges, customs fees, duties, and taxes, if applicable, are the responsibility of the buyer. No returns will be accepted after 60 days of receipt of shipment. Refunds will not be issued for custom or special order parts. Restocking fees and/or freight charges will not be applicable in the case of defective, incorrect, or damaged merchandise. Final credit is subject to inspection and acceptance of returned material.

McMASTER-CARR® 1420

630-600-3600
 630-834-9427 (fax)
 chi.sales@mcmaster.com

Invoice

Purchase Order	209103
Total	\$6.12
Invoice	77527876
Invoice Date	3/17/14
Payment Terms	2% 10, Net 30
Deduct \$0.04 on merchandise if paid by 3/27/14.	

Billed to
 KRAEMER CO LLC
 820 WACHTER AVE
 PLAIN WI, 53577

RECEIVED

MAR 21 2014

Shipped to
 Kraemer Co LLC
 840 Wachter Ave
 Plain WI 53577

Mail Payment to
 McMaster-Carr
 PO Box 7690
 Chicago IL 60680-7690

Your Account
 138633800

Doug placed this order.

Line	Product	Ordered	Shipped	Balance	Price	Total
1	6214K26 Comfort-Grip Knurled-Rim Knob, 1/4"-20 Threaded Insert, 1-9/16" Diameter	1 Each	1	0	1.81 Each	1.81
Merchandise						1.81
Shipping						4.31
Total						\$6.12

Packing List	Shipped	Weight	Carrier	Tracking
1285667-01	3/17/14	1 lb	Spee-Dee Delivery	1Z0062500383516440

TAX EXEMPT

- 3672 - 11 - 14
 [Signature]



CONNNEY SAFETY

A DIVISION OF WESCO DISTRIBUTION, INC.

ACCOUNTS RECEIVABLE:
PHONE: 800-532-1860
FAX: 800-854-7932
conney.com

PAGE 1

INVOICE

1139

S
H
I
P

T
O

M
A
I
L

T
O

3202 Latham Drive | PO Box 44575 | Madison, WI 53744-4575
THE KRAEMER COMPANY LLC
ATTN MIKE ANLIKER
840 WACHTER AVE
PLAIN WI 53577

INVOICE NUMBER: 04642260
INVOICE DATE: 3/13/14
CUSTOMER NUMBER: 100023543
P.O. NUMBER: 511021
ORDERED BY: MIKE ANLIKER
TERMS: Net 60 days

THE KRAEMER COMPANY LLC
PO BOX 235
PLAIN WI 53577

DATE ENTERED: 3/13/14
F.O.B. :
SHIPPED VIA: UPSGD
ORDER NUMBER: V59Q5/01
TERRITORY: 582
SHIPPING DATE: 3/13/14

RECEIVED
MAR 17 2014

BY: _____

ITEM NUMBER	UNIT	DESCRIPTION	SIZE, COLOR STYLE OR PACK	QUANTITIES			UNIT PRICE	AMOUNT
				ORDERED	B.O.	SHIPPED		
173720	PK	LBL ENGR 110 VOLTS 3.5X5	5S LELC	2		2	13.78	27.56T
93181	PK	LBL ENGR 220 VOLTS 5S	3.5X5 LELC	2		2	10.60	21.60T
64726VS	EA	SGN DGR NO SMOKING MATCH OPEN WY	7X10 MSMK	10		10	8.21	82.10T
64909VS	EA	SGN DGR HEARING PRTECTN RQ W/S WY PROMQ APPLIED	7X10 NPFE	10		10	8.21	82.10T

GSA CONTRACT INFORMATION AND TERMS AND CONDITIONS ARE ON REVERSE SIDE
MATERIAL SAFETY DATA SHEETS ARE AVAILABLE UPON REQUEST

Merchandise: 213.36
Tax: 11.75 ✓
Shipping and Handling:

Subtotal: 225.11
Pre-paid:

**SATISFACTION GUARANTEED
THANK YOU FOR YOUR ORDER**

USD **225.11**

REMITTANCE DOCUMENT: TO INSURE PROPER CREDIT, PLEASE DETACH THIS PORTION AND RETURN WITH REMITTANCE.

B
I
L
L
T
O

THE KRAEMER COMPANY LLC
PO BOX 235
PLAIN WI 53577

COMPANY: 1

CUSTOMER NUMBER: 100023543

R
E
M
I
T
T
O

CONNNEY SAFETY
P O BOX 44575
MADISON WI 53744-4575

INVOICE NUMBER: 04642260

INVOICE DATE: 3/13/14

AMOUNT DUE: 225.11

Machine Control Specialists ¹⁴⁰⁰

820-B Moasis Drive
P.O. Box 205
Little Chute, WI 54140
920-788-8052
dan.steiner@mcscontrol.com

Invoice

DATE	INVOICE #
2/26/2014	3629

BILL TO
Kraemer Company 820 Wachter Avenue P.O. Box 235 Plain, WI 53577

SHIP TO
Kraemer Company 820 Wachter Avenue P.O. Box 235 Plain, WI 53577

BY:.....

P.O. NUMBER	TERMS	DUE DATE	SHIP	VIA	F.O.B.	PROJECT
209051	Net 30	3/28/2014	2/24/2014	US Special		3633
QUANTITY	ITEM CODE	DESCRIPTION			PRICE EACH	AMOUNT
1	Fabrication	Control Panel for 1) 60HP Fan, 3) 5HP Augers, 1) 10HP Auger and 1) Warning Alarm Unit# 8672			9,850.00	9,850.00
1	Freight	SHIPPING CHARGES			155.33	155.33
<p><i>8672-10-14</i> <i>17%</i></p>						
<p>TAX EXEMPT</p>						
Thank you for your business.					Total	\$10,005.33

Service charge will be assessed to all past due amounts at the rate of 1.5% per month

Great people, great products, great prices!



AUTO PARTS

PETERSON'S AUTO PARTS
505 WATER STREET
SAUK CITY, WI 53583
608-643-3329

1510

PAGE 1 OF 2
REF# 138099

RIGHT PLACE, RIGHT PARTS, RIGHT PRICE!



21201401280558600001138040000138099280

ANY PRODUCT RETURNED FOR CREDIT MUST BE ACCOMPANIED BY THIS RECEIPT.

SEE CARQUEST STORE FOR DETAILS OF THE COAST TO COAST GUARANTEE.

B
I
L
T
O
KRAEMER COMPANY, LLC
820 WACHTER AVE/P O BOX 235
PLAIN, WI 53577-0235

S
H
I
P
T
O
THE KRAEMER COMPANY LLC
WM. J. KRAEMER/JOSEPH KRAEMER

COEXP101

INVOICE NO.	CUSTOMER NO.	DATE	CUST. P.O. NO.		SALES ID	TEAMMATE ID	FORM OF PYMT.		
5586-113804	3965	01/28/14	209004		SALES	GREG	CHARGE		
MFG. PART NUMBER			ORDERED	SHIPPED	LIST PRICE	NET	NET CORE	EXT. AMOUNT	TAX
1 DIC RHD-S5 IMRON 3.5 HG+ HIGH GLOSS MIX			8	8	1132.18	679.31	0.00	5434.48	N/N
2 DIC 9T00A-01 ACTIVATOR HC64			8	8	299.43	179.66	0.00	1437.28	N/N
3 DIC LF-63325P-05 2.1 ST SHALE GRAY HC61			4	4	597.18	358.31	0.00	1433.24	N/N
4 DIC VF-525-05 2.1 ST ACTIVATOR HC63			4	4	600.48	360.29	0.00	1441.16	N/N
5 DIC Y32035-01 DUPONT THINNER HC63			5	5	48.15	28.89	0.00	144.45	N/N
WARRANTY DISCLAIMER: The manufacturer's warranty, if any, constitutes the only warranty with respect to the sale of all goods. SELLER HEREBY EXPRESSLY DISCLAIMS ALL WARRANTIES, EITHER EXPRESSED OR IMPLIED, INCLUDING ANY IMPLIED WARRANTY OF MERCHANTABILITY OR FITNESS FOR A PARTICULAR PURPOSE. Seller does not authorize any person to grant any warranty or assume any liability by Seller.									
SHIP VIA	DELV. TIME	DELV. ID	FREIGHT	TAXABLE AMT.	SALES TAX	TOTAL CORE	PREV. DEPOSIT		

09:55 AM

RECEIVED BY X

CUSTOMER COPY

PAY THIS AMOUNT

CONTINUED

Great people, great products, great prices!™



AUTO PARTS

PETERSON'S AUTO PARTS
505 WATER STREET
SAUK CITY, WI 53583
608-643-3329

PAGE 2 OF 2
REF# 138099

RIGHT PLACE, RIGHT PARTS, RIGHT PRICE!



21201401280558600001138040000138099280

ANY PRODUCT RETURNED FOR CREDIT MUST BE ACCOMPANIED BY THIS RECEIPT.

SEE CARQUEST STORE FOR DETAILS OF THE COAST TO COAST GUARANTEE.

B
I
L
T
O
KRAEMER COMPANY, LLC
820 WACHTER AVE/P O BOX 235
PLAIN, WI 53577-0235

S
H
I
P
T
O
THE KRAEMER COMPANY LLC
WM. J. KRAEMER/JOSEPH KRAEMER

COEXP101

INVOICE NO.	CUSTOMER NO.	DATE	CUST. P.O. NO.		SALES ID	TEAMMATE ID	FORM OF PYMT.		
5586-113804	3965	01/28/14	209004		SALES	GREG	CHARGE		
MFG. PART NUMBER			ORDERED	SHIPPED	LIST PRICE	NET	NET CORE	EXT. AMOUNT	TAX
6 DIC 9M01-01 IND STRENGTH THIN HC61			4	4	98.58	59.15	0.00	236.60	N/N
8672-10-17 DC									
TAX EXEMPT									
WARRANTY DISCLAIMER: The manufacturer's warranty, if any, constitutes the only warranty with respect to the sale of all goods. SELLER HEREBY EXPRESSLY DISCLAIMS ALL WARRANTIES, EITHER EXPRESSED OR IMPLIED, INCLUDING ANY IMPLIED WARRANTY OF MERCHANTABILITY OR FITNESS FOR A PARTICULAR PURPOSE. Seller does not authorize any person to grant any warranty or assume any liability by Seller.									
SHIP VIA	DELV. TIME	DELV. ID	FREIGHT	TAXABLE AMT.	SALES TAX	TOTAL CORE	PREV. DEPOSIT		

09:55 AM

RECEIVED BY X

CUSTOMER COPY

PAY THIS AMOUNT

10127.21